

**CCB-CCT-0002 E**

**ADDENDUM**

**to**

**LGSOWG CCT Format  
CCB Document:**

**The  
Standard CCT Family  
of Tape Formats**

**for**

**File Class: IMOP - Imagery Options**

**December 18,1988**

# COMPARISON BETWEEN FILE CLASSES

## IMGY - IMAGERY FILE

### IMOP - IMAGERY OPTIONS FILE

The file class IMOP is similar to file class IMGY but has four additional features.

#### 1. Pad Pixels Present Indicator

'Pad Pixels' are the left and right fill pixels inserted next to the imagery pixels in order to apply line-to-line registration (e.g., for earth rotation correction). A count of pad pixels on a line-by-line basis is usually supplied in each image data record prefix area. If the 'Pad Pixels Present Indicator' is set to 'Absent', then the count of pad pixels given on a line-by-line basis indicates the number of pad pixels which should be inserted to achieve line-to-line registration. (This feature was introduced to keep image data records as short as possible, and thereby save space on magnetic tapes.) It should be noted that IMGY and IMOP use left, right, top and bottom border pixels and lines in an identical fashion.

#### 2. Pad Bits Within Data Group

When individual pixels are not integral multiples of 8 bit bytes (e.g., 10 bits), it is usually more convenient to store each pixel in the next largest multiple of 8 bit bytes (e.g., 2 bytes = 16 bits), and to insert a combination of left fill bits and right fill bits (e.g., 6 bits total) to fill out the data group. In the IMGY case, these left fill and right fill bits are zero-filled. In the IMOP case, these fill bits can be used for other purposes, such as coastline grids or latitude/longitude grids. The data description of these bits is inserted as a code in fields which were blank filled in the IMGY case. Using the example of 10 bit pixels right justified in two bytes, the following table shows the interpretation of fields in the PIXEL GROUP DATA area and the PIXEL DATA DESCRIPTION area of the file descriptor record variable scgmnt.

FIELD	IMGY	IMOP	DESCRIPTION
4	16	10	No. of bits per pixel
5	1	1	No. of pixels per data group
6	2	2	No. of bytes per data group
35	6	6	No. of left fill bits per pixel
36	0	0	No. of right fill bits per pixel
37	1023	1023	Maximum data range
38		\$\$\$\$CL\$\$	Left fill bits description where S = State Boundary; C = Coastline Grid; L = Lat/Long Grid
39			Right fill bits description

It should be emphasised that in the IMGY case, the left fill bits are considered to be part of the image pixel (no. of bits per pixel = 16) whereas, in the IMOP case, they are not (no. of bits per pixel = 10).

#### 3. Data Organisation

Both IMGY and IMOP can use BIL (Band Interleaved by Line), BSQ (Band sequential) BIP (Band Interleaved by Pixel), BInn, BSnn and Nnnn organisations (see Field 15 Interleaving Indicator for full details). However, an additional feature is available in IMOP, namely, LInn (and Lnnn). LInn (and Lnnn) is similar to the BInn (and Nnnn) option, but with two major differences. Firstly, the prefix and suffix area occur once only per physical image data record. Secondly, the individual bands may have different resolutions, i.e. the pixel data descriptions are different for each band.

#### 4. Data Format Type Indicator

File class IMOP permits the detailed definition of image data pixel representation. e.g., complex, hexadecimal.

**TABLE 1      IMAGERY OPTIONS FILE-FILE DESCRIPTOR VARIABLE  
SEGMENT-DEFINITION**

<u>NO.</u>	<u>BYTE</u>	<u>DEFINITION</u>
1	1-6*	Number of image records per band.  (* Byte 1 of the variable segment is byte 181 of the record.)
2	7-12	Record length.
3	13-36	Reserved (blanks).
PIXEL GROUP DATA		
4	37-40	Number of bits per pixel.
5	41-44	Number of pixels per data group.
6	45-48	Number of bytes per data group.
7	49-52	Justification and order of pixel within data group.
IMAGE DATA		
8	53-56	Number of bands of imagery in this file.
9	57-64	Number of lines per band excluding top and bottom border lines.
10	65-68	Number of left border pixels.
11	69-76	Number of image pixels per line.
12	77-80	Number of right border pixels.
13	81-84	Number of top border lines.
14	85-88	Number of bottom border lines.
15	89-92	Interleaving indicator.
RECORD DATA		
16	93-94	Number of physical records per line.
17	95-96	Number of physical records per multispectral line in this file.
18	97-100	Number of bytes of prefix data per record
19	101-108	Number of bytes of image data per scan line per band (in a record).
20	109-112	Number of bytes of suffix data per record.
21	113-116	Prefix/suffix repeat flag.
PREFIX/SUFFIX DATA LOCATORS		
22	117-124	Scan line number locator.
23	125-132	Band number locator.
24	133-140	Time of scan line locator.
25	141-148	Left-fill count locator.
26	149-156	Right-fill count locator.
27	157-160	Pad pixels present indicator.
28	161-188	Blanks.
29	189-196	Scan line quality code locator.
30	197-204	Calibration information locator.
31	205-212	Gain values field locator.
32	213-220	Bias values field locator.
33	221-248	Data format type indicator.
34	249-252	Data format type indicator code.
35	253-256	Number of left fill bits within pixel.
36	257-260	Number of right fill bits within pixel.

**TABLE 1 (con't.)      IMAGERY OPTIONS FILE-FILE DESCRIPTOR  
VARIABLE SEGMENT-DEFINITION**

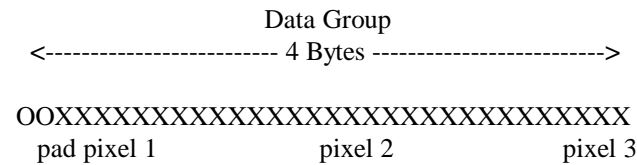
<u>NOS.</u>	<u>BYTE NOS.</u>	<u>DEFINITION</u>
37	261-268	Maximum available data range of pixel (from zero).
38	269-276	Left-fill pixel bits data description.
39	277-284	Right-fill pixel bits data description.
40	285-288	Number of bands per line for LInn interleaving.
41	289- (289+16NN)	Pixel group data for LInn interleaving.
42	(289+16NN+1)- (289+48NN)	Pixel data description for LInn
43	(289+48N+1)- (EOR)	Blanks.

**TABLE 2      IMAGERY OPTIONS FILE - FILE DESCRIPTOR VARIABLE  
SEGMENT-EXPLANATION**

<u>FIELD NUMBER</u>	<u>DESCRIPTION</u>
1	Total number of image records in the file.
2	Length of image records in the file.
3	A blank field required for consistency in variable segment formats.

**PIXEL GROUP DATA**

When pixel values are not even byte multiples in length, either each pixel must be padded so as to have the value field length fall on byte boundaries, or the pixels must be grouped so that the group of values plus padding fall on byte boundaries. For example, if each pixel is 10 bits, the pixel group could be arranged as follows:



The pixel group of this file is described in the following four fields:  
 A description of the data value content within each pixel is given in fields 4 to 7.

4	Number of bits per pixel.
5	Number of pixels per data group.
6	Number of bytes per data group.
7	Justification and order of pixels within data group. This information is given in code.

**TABLE 2 (con't) IMAGERY OPTIONS FILE-FILE DESCRIPTOR VARIABLE  
SEGMENT EXPLANATION**

<u>FIELD NUMBER</u>	<u>DESCRIPTION</u>
	RJLR - The pixels are right justified (i.e., the pad is on the left) with the first pixel leftmost (i.e., pixel order is leftmost).
	RJRL - The pixels are right justified with the first pixel rightmost
	ULR - The pixels are left-justified with the first pixel leftmost
	LJRL - The pixels are left-justified with the first pixel rightmost
	\$\$\$\$ - Pixel value lengths fall on byte boundaries.
	For LInn and Lnnn, fields 4,5 and 6 are zero-filled, and field 7 is blank-filled. The LInn and Lnnn pixel group data are detailed in Field 41.
8	The number of bands in this file.
9	Number of lines per band excluding border lines.
10	The number of border pixels to the left of the image pixels for each band.
11	Total number of image pixels allocated per scan line or scan line segment per band.
12	The number of border pixels to the right of the image pixels for each band.
13	The number of scan lines per band of border above the image.
14	The number of scan lines per band of border below the image.
15	A code indicating data interleaving:
	BSQS - Band sequential, one (or part of one) scan line per physical record.
	DSnn - Band sequential, nn scan lines per physical record. Prefix and suffix areas are repeated for EACH band.
	Snnn - Similar to Snnn, but nnn scan lines per record.
	BILS - Band interleaved by line, one (or part of one) scan line for one band per physical record.
	BIIn - Band interleaved by line, a maximum of nn band per physical record, with only the last physical record of the multispectral line areas are repeated being padded on the right. The prefix and suffix for EACH band.
	Nnnn - Similar to BLnn, but nnn bands per record.
	LInn - Band interleaved by line, a maximum of nn bands per physical record, with only the last physical record of the multispectral line being padded on the right This option differs from BInn in three significant ways:
	(a) different bands may have different resolutions;

TABLE 2 (con't)

**IMAGERY OPTIONS FILE-FILE DESCRIPTOR VARIABLE  
SEGMENT-EXPLANATION**

<u>FIELD NUMBER</u>	<u>DESCRIPTION</u>
	(b) pixel pad bits may be used for storing additional information; and (c) the prefix and suffix are not repeated for each band. However, when more than one physical record is required to store all the bands, the prefix and suffix areas are retained in EACH physical record.
	Lnnn - Similar to LInn, but nnn bands per record.
	BIP\$ - Band interleaved by pixel, one multispectral scan line per physical record.
	BIPn - Band interleaved by n pixels, one multispectral scan line per physical record. (BIPi represents the same layout as BIP\$.)
16	Number of physical records per band per scan line, coded 0 if less than one. This field is not applicable to BIP interleaving and is coded 0.
17	Number of physical records per multispectral line ~ It may be less than one for multiple scan lines per physical record (BSnn), in which case it is coded 0.
18	The length of the prefix support data field associated with each scan line of each band (it may include scan line identifier, right and left fill count, etc.) For BIPn interleaving, there is only one prefix data area per physical record.
19	This includes left and right borders. For BIPn interleaving, it is the total number of bytes of image data within the record
20	The length of the suffix support data field associated with each scan line of each band. It may include scan line quality code, gain and bias values etc. For BIPn interleaving there is only one suffix data area per physical record.
21	This field is applicable in two cases, i.e., EITHER when one scan line requires more than one physical record (BSQ or BIL) OR when the LInn organisation is used and more than one record is required to store all bands. In both cases, this field will indicate whether the prefix and suffix fields are repeated in each record. When the prefix and suffix fields are not repeated, they are zero-filled to maintain pixel alignment.
	R\$\$\$ means they are repeated, and \$\$\$\$ means they are not
22-26	Prefix data locators - while all of the preceding fields give information about the data in the imagery file, the next five fields are reserved providing locators which point to the location of data within the record prefix. The location is given in 8 bytes as follows:  4 bytes - giving the byte number within the prefix or suffix which begins the field to be located; 2 bytes - giving the length in bytes of the field to be located; 1 byte - the letter P or S in this byte indicates that the information is in the scan line prefix or suffix, respectively; and 1 byte - a code indicating the type of data in the field. A means Alphanumeric in ASCII or EBCDIC, B means Binary, and N means Numeric in ASCII or EBCDIC.

for  
image

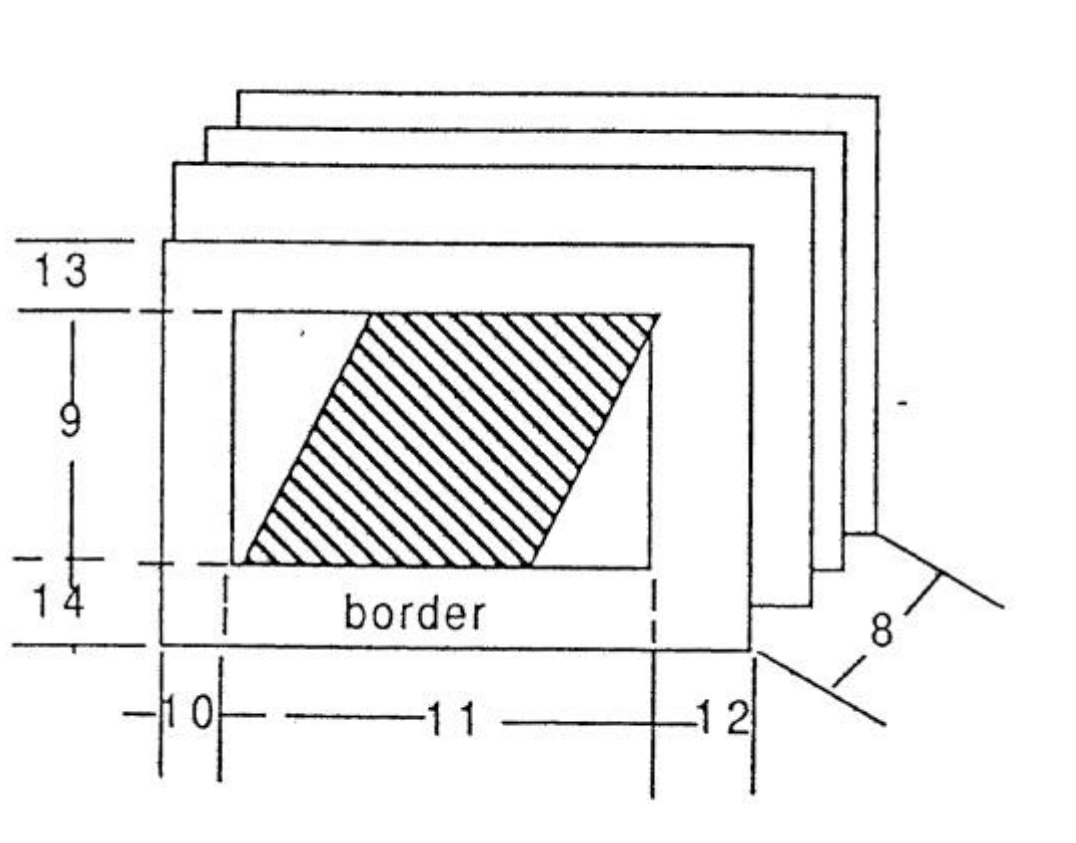
**TABLE 2 (con't)                   IMAGERY OPTIONS FILE-FILE DESCRIPTOR VARIABLE  
SEGMENT-EXPLANATION**

<u>FIELD NUMBER</u>	<u>DESCRIPTION</u>
27	Pad pixels present indicator is coded with blanks if left and right pad pixels are present (e.g. for Earth rotation correction) in image line data, or coded with ones if they are not present. In the latter case, the count of left fill pixels should be interpreted to mean the amount of left fill pixels, need to be inserted to obtain the correct geometric alignment between adjacent scan lines (e.g. for Earth rotation correction).
which	
29-32	Suffix data locators - same definition as for Prefix data locators, defined for fields 22-26. There are four fields for these locators.
33-34	This is a 28 character string to describe the data format, followed by a 4 character code. To allow for a more unique specification of the data formats, FORTRAN-like conventions have been adopted. The convention is illustrated by the following examples.
	<pre> INTEGER* 1\$\$\$\$\$\$\$\$\$\$\$\$\$\$\$\$&amp; I* 1\$ INTEGER* 2\$\$\$\$\$\$\$\$\$\$\$\$\$\$\$\$&amp; I* 2\$ INTEGER* 4\$\$\$\$\$\$\$\$\$\$\$\$\$\$\$\$&amp; I* 4\$ SIGNED-INTEGERS* 1\$\$\$\$\$\$\$\$\$\$\$\$ IS 1\$ REAL*8\$ R*8\$ REAL*8\$HEXADECIMAL\$\$\$\$\$\$\$\$ R* 8H COMPLEX*4\$\$\$\$\$\$\$\$\$\$\$\$\$\$\$\$ C*4\$ COMPLEXSINTEGERS*8\$\$\$\$\$\$\$\$\$\$\$\$ CI*8 COMPLEX\$SIGNEDSINTEGERS*8\$\$\$\$ CIS8 COMPLEX*8\$HEXADECIMAL\$\$\$\$\$\$\$\$ C*8H </pre>
complex 8	Note: *8H is Eight-byte hexadecimal floating point representation with the exponent denoted as a hexadecimal exponent. (Note that the real and byte representations are the same as double precision)
35-39	For LInn and Lnnn, fields 35, 36 and 37 are zero-filled, and fields 38 and 39 are blank-filled.
38-39	These 8 bytes provide information on the precise way in which each of the left (and right) pixel fill bits h3ve been used (maximum of eight left fill and eight right fill bits). Codes TBD.
40	Number of bands per multispectral line (i.e., number of single-band-lines) for LInn organisation only.
41	Pixel group data for all nn bands in LInn organisation. There are nn 16 byte data descriptions, each coded as described for fields 4 through 7.
42	Pixel data description for all nn bands in LInn organisation. There are nn 32 byte data descriptions, each coded as described for fields 35 through 39.

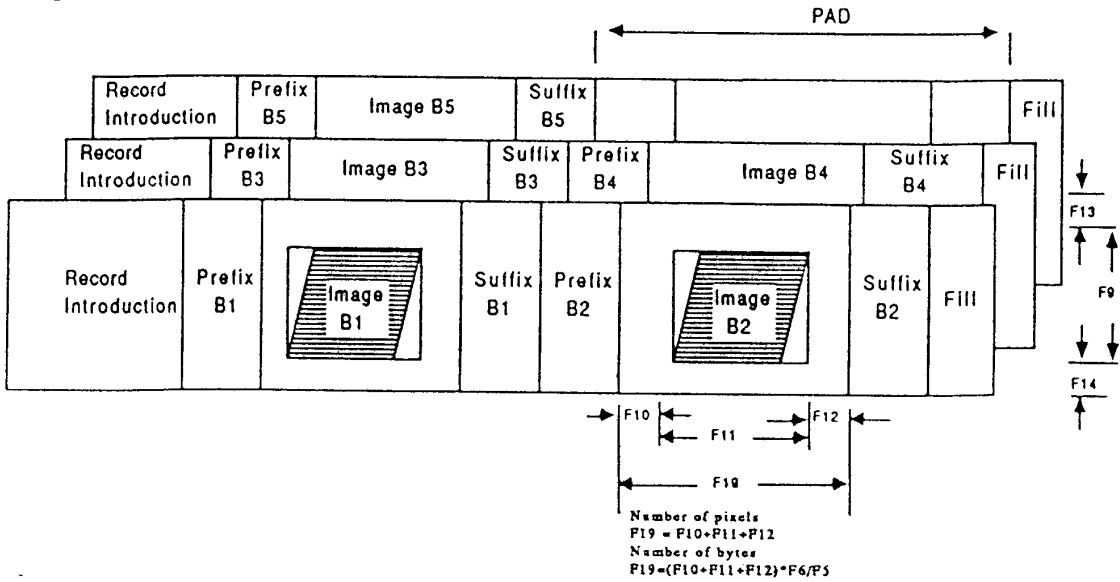
## IMAGE DATA

The following diagram will be used as an example in explaining the image data parameters. I represents a scene of four bands of geometrically corrected (hence the skew) image data with borders. The numbers indicate the respective fields of the variable segment.

Note: The shaded area represents image pixels. Unshaded pixels within the border represent pad pixels. These are the left and right fill pixels inserted to apply line-to-line registration (e.g. earth rotation correction). A Count of pad pixels on a line-by-line basis is usually supplied in each image data record. If field 27 is blank filled, pad pixels will be present. If field 27 is coded with 1's (i.e. 1111) then the pad pixels are NOT present. In this case, the count of pad pixels given on a line-by-line basis is the number of pad pixels which should be inserted to achieve line-to-line registration.

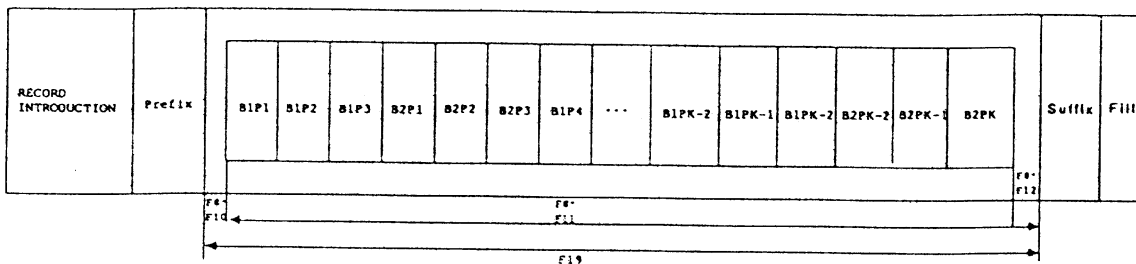


**Diagram 1 Image Data Parameters, B<sub>Inn</sub> or B<sub>Snn</sub>**



Number, nn, of bands per second = F15 (Binn)  
 OR  
 Number, nn, of scan lines per record = F15 (Bsnn)

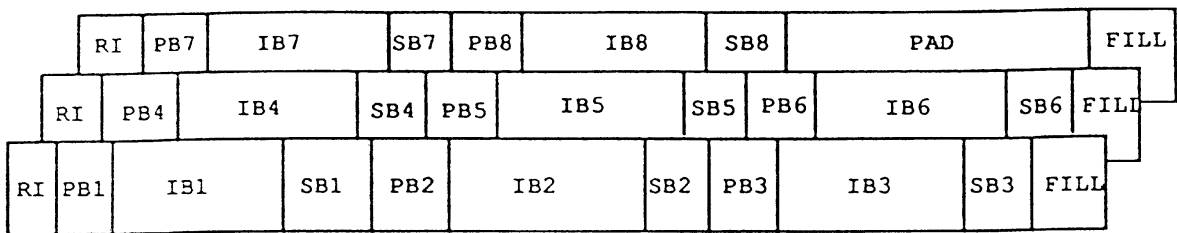
**Diagram 2 Image Data Parameters, BIP<sub>n</sub> Example of BIP3, 3 Bands**



Number of pixels =  $F_8 * (F_{10} + F_{11} + F_{12})$   
 Number of bytes =  $F_{19} = F_8 * (F_{10} + F_{11} + F_{12}) * F_6 / F_5$

Number, n, of pixels in interleaving group = F15(BIP<sub>n</sub>)  
 Number, m, of bands per record = F8  
 Number of physical records per line, F16 = 0  
 Number of physical records per multispectral line, F17 = 1

**Diagram 3 Record Construction Example of BI03, 8 Bands**

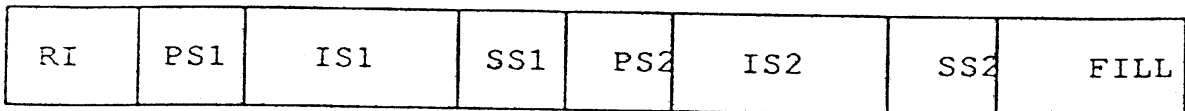


In this example there are three bands of imagery stored in each physical record.

Since there are a total of eight bands of imagery, three physical records are required to accommodate one multispectral line.

- RI = Record Introduction
- PBm = Prefix for Band m
- IBm = Imagery for Band m
- SBm = Suffix for Band m

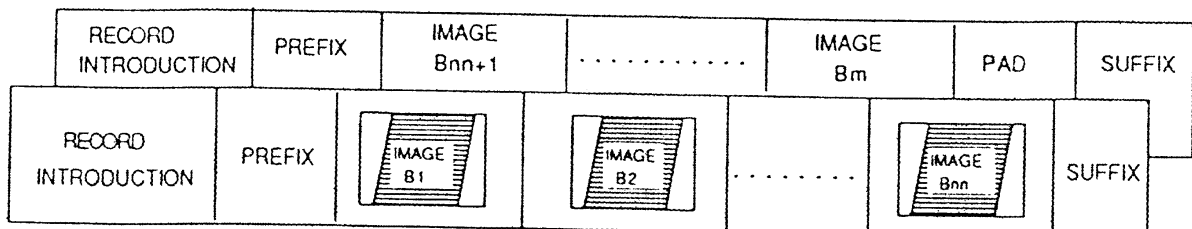
**Diagram 4 Record Construction Example of BSO2**



In this example there are two scan lines of imagery stored in each physical record.

- RI = Record Introduction
- PSm = Prefix for Scan line m
- ISm = Imagery for Scan line m
- SSm = Suffix for Scan line m

**Diagram 5 Image Data Parameters File Class IMOP, Lnn organisation**



Number, nn, of bands per record = P15 (Lnn)

Total number of bands = m = F8

Copyright C CEOS 1999

The Copyrighter grants permission for personal use and distribution to other parties provided the information is not changed and any copyright notices in the document are reproduced.